

Check, Relief & Excess Flow Valves

The best partner for value creation
We support the innovations of customers



03



Catalogue No. S-LOK Jan.2023

SCV30 Series Check Valves

Features

- Pressure rating up to 3,000psig (206bar) @70°F(21°C).
- Temperature rating up to 375°F(191°C) with Standard FKM O-ring.
- Choice of materials : Standard S316 and Brass.
- Cracking pressures include : 1/3, 1, 3, 10, 25, 50psi.
- Heat code traceability.
- Every valve is 100% factory tested for cracking and reseal.



Features

- Ensures Valve closes bubble tight

Fixed Cracking Pressures

- From 1/3psi to 50psi

Back stopped Poppet

- Minimize Spring stress

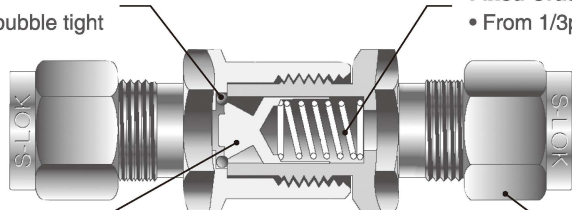

Various End Connections

- include S-LOK Tube Fittings
- NPT & ISO Male/Female Threads

Technical Data

Valve Series	SCV1, SCV2, SCV3, SCV4	SCV5, SCV6
Max. Working Pressure @70°F(21°C)	SS316 and Brass : 3000psi (206bar)	SS316 : 2000psi (137bar) Brass : 1500psi (103bar)
Operating Temperature Range	FKM : -10°F to 375°F(-23°C to 190°C) NBR : -4°F to 221°F(-20°C to 105°C)	
Nominal Cracking Pressure	1/3, 1, 3, 10, 25, 50psi	

Cracking, Reseal and Back Pressure

Cracking Pressure

The upstream pressure at which a detectable flow is Measured. The Check valve is actuated when the pressure difference between the inlet and the outlet reaches the range of cracking pressure.

Reseal Pressure

The downstream pressure at which the check valve closes bubble-tight. The Check valves that have higher cracking pressure can be resealed to bubble-tight by the spring force. The reseal pressure is the pressure at the same flow direction, but lower than the cracking pressure.

Back Pressure

The Check valves that have cracking pressure 5psig(0.34bar) and lower may not be able to return to the bubble-tight seal. This may require back pressure to press the seal to form a bubble-tight contact in addition to the spring force.

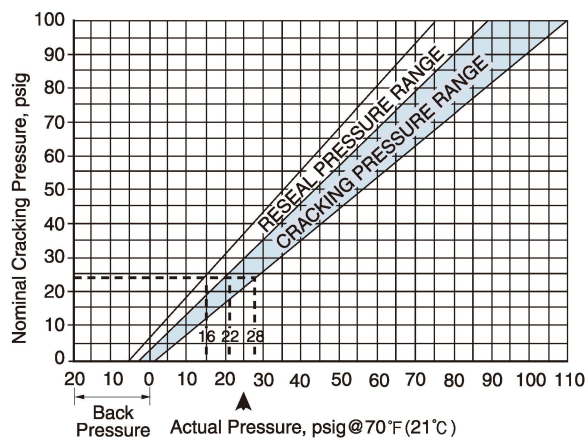

Note

- When the check valve is not actuated for a period of time, it may require initially crack at higher than the above cracking pressure ranges.
- Check valves are designed for directional flow control only. Therefore HANSUN check valves should never be used as code Safety relief devices.

Materials of Construction

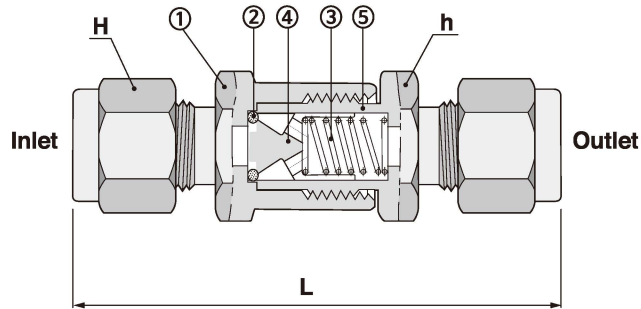

Item	Description	Materials	
		SS316	Brass
1	Body	SS316 / A479 or A276	Brass
2	Connector		
3	Poppet	SS304	
4	Spring	SS304	
5	O-ring	FKM	

* Silicone-based Lubricant for poppet.

Ordering Information and Dimensions

Basic Ordering Number	Orifice mm(inch)	Cv	End Connections Inlet/Outlet	Dimensions(mm)			
				h	H	L	
SCV1	S-2T	2.28(0.09)	0.16	1/8" S-LOK	15.88(5/8)	11.11(7/16)	55.60(2.19)
	M-2N			1/8" Male NPT		-	44.40(1.75)
	F-2N			1/8" Female NPT		-	46.50(1.83)
	S-4T			1/4" S-LOK		14.29(9/16)	60.00(2.36)
	S-6M			6mm S-LOK		14.00	-
	MS-4N4T			1/4" Male NPT 1/4" S-LOK		14.29(9/16)	56.40(2.22)
	M-4N			1/4" Male NPT		-	53.40(2.10)
SCV2	F-4N	7.1 (0.28)	1.48	1/4" Female NPT	19.05(3/4)	-	56.80(2.24)
	S-6T			3/8" S-LOK"		17.46(11/16)	65.50(2.58)
	S-10M			10mm S-LOK		19.00	-
	M-6N			3/8" Male NPT		-	55.50(2.19)
SCV3	F-6N	10.0 (0.39)	1.7	3/8" Female NPT	22.22(7/8)	-	63.80(2.51)
	S-8T			1/2" S-LOK		22.22(7/8)	80.20(3.16)
	S-12M			12mm S-LOK		22.00	-
	M-8N			1/2" Male NPT		-	74.40(2.93)
SCV4	F-8N	13.5 (0.53)	2.6	1/2" Female NPT	28.58(1-1/8)	-	84.70(3.33)
	S-10T			5/8" S-LOK		25.40(1)	91.80(3.61)
SCV5	S-12T	16.0 (0.63)	5.2	3/4" S-LOK	31.75(1-1/4)	28.58(1-1/8)	110.70(4.35)
	M-12N			3/4" Male NPT		-	105.30(4.15)
	F-12N			3/4" Female NPT		-	103.00(4.06)
SCV6	S-16T	18.0 (0.71)	8.0	1" S-LOK	41.28(1-5/8)	38.1(1-1/2)	121.10(4.77)
	M-16N			1" Male NPT		-	116.20(4.57)
	F-16N			1" Female NPT		-	111.40(4.39)

Spring Cracking, Reseal and Back Pressure at @70°F(21°C)

Spring Nominal Cracking Pressure		Cracking Pressure Ranges				Reseal Pressure	
psig	bar	Min. Pressure psig	bar	Max. Pressure psig	bar	psig	bar
1/3	0.02	0	0	3	0.21	Up to 6	0.41
1	0.07	0	0	4	0.28	Back pressure	0.34
						Up to 5	0.28
3	0.21	2	0.14	7	0.48	Back pressure	0.21
						Up to 4	0.21
10	0.69	7	0.48	15	1.03	3	0.21
25	1.72	20	1.38	30	2.07	17	1.17
50	3.45	40	2.76	60	4.14	35	2.41
75	5.17	60	4.14	90	6.2	53	3.65
100	6.89	80	5.51	120	8.27	70	4.82

Pressure-Temperature Ratings

Ratings based on FKM O-ring in SS316 stainless steel valves and NBR O-ring in brass valves.

Series	SCV1, SCV2 SCV3, SCV4		SCV5, SCV6	
Temperature °F(°C)	Working Pressure, psig (bar)			
	SS316	Brass	SS316	Brass
-10(-23) to 100(37)	3000(206)	3000(206)	2000(137)	1500(103)
200(93)	2575(177)	2600(179)	1715(118)	1300(89)
250(121)	2450(168)	2405(165)	1630(112)	1250(86)
300(148)	2325(160)	-	1545(106)	-
375(190)	2185(150)	-	1450(99.9)	-
400(204)				

SCP30 Series Compact One Piece Check Valves

Features

- Pressure rating up to 3,000psig (206bar) @70°F(21°C).
- Temperature rating up to 375°F(191°C) with Standard FKM O-ring.
- Compact one-piece body.
- Fully contained O-ring seal blow-out proof design.
- Choice of materials : Standard S316 and Brass.
- Cracking pressures include : 1/3, 1, 3, 10, 25, 50psi.
- Heat code traceability.
- Every valve is 100% factory tested for cracking and reseal.



Materials of Construction

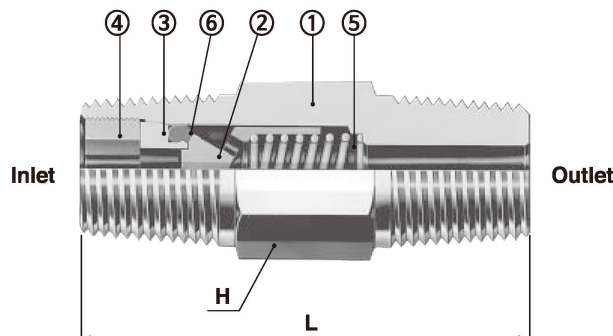

Item	Description	Materials	
		SS316	Brass
1	Body	SS316 / A276 or A479	Brass
2	Poppet		
3	Insert		
4	Locking Screw		
5	Spring	SS304	
6	O-ring	FKM	NBR

* Silicone-based Lubricant for poppet.

Ordering Information and Dimensions

Basic Ordering Number		Cv	End Connections			Dimensions mm(inch)	
			Size	Inlet	Outlet	L	H
SCP1	M-4N	0.35	1/4"	Male NPT		41.1(1.62)	14.28(9/16)
	M-4R		Male ISO				
	F-4N		Female NPT		61.2(2.41)	19.05(3/4)	
	F-4R		Female ISO		64.5(2.54)		
	MF-4N		Male NPT	Female NPT	44.4(1.75)		
	FM-4N		Female NPT	Male NPT	58.2(2.29)		
SCP2	M-8N	1.20	1/2"	Male NPT		57.9(2.28)	22.22(7/8)
	F-8N		Female NPT		94.2(3.71)	26.98(1-1/16)	
	MF-8N		Male NPT	Female NPT	71.9(2.83)		

All dimensions shown are for reference only and are subject to change.

Spring Cracking, Reseal and Back Pressure at @70°F(21°C)

Spring Nominal Cracking Pressure		Applied Working Pressures-psig(bar)				Reseal Pressure	
		Min. Pressure		Max. Pressure			
psig	bar	psig	bar	psig	bar	psig	bar
1/3	0.02	0	0	3	0.21	up to 6	0.41
						Back pressure	
1	0.07	0	0	4	0.28	up to 5	0.34
						Back pressure	
10	0.69	7	0.48	15	1.03	3	0.21
25	1.72	20	1.38	30	2.07	17	1.17

SCA30 Series Adjustable One Piece Check Valves

Features

- Pressure rating up to 3,000psig (206bar) @700°F(21°C).
- Cracking pressure adjustable from 3 to 600psi (0.2 to 41.4 bar)
- Temperature rating up to 375°F(191°C) with Standard FKM O-ring.
- Choice of materials : Standard S316 and Brass.
- Compact one-piece body.
- Heat code traceability.
- Every valve is 100% factory tested for cracking and reseal.



Materials of Construction

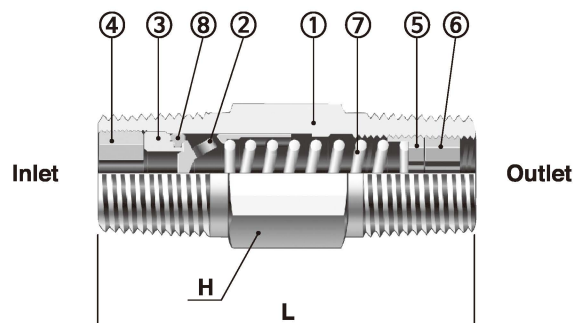

Item	Description	Materials	
		SS316	Brass
1	Body	SS316 / A276 or A479	Brass
2	Poppet		
3	Insert		
4	Insert Lock Screw		
5	Adjusting Screw		
6	Locking Screw	SS304	
7	Spring		
8	O-ring	FKM	NBR

* Silicone-based Lubricant for poppet.

Ordering Information and Dimensions

Basic Ordering Number		Cv	End Connections			Dimensions mm(inch)	
			Size	Inlet	Outlet	L	H
SCA1	F-4N	0.35	1/4"	Female NPT		75.7(2.98)	19.05(3/4)
	M-4N		Male NPT		41.1(1.62)	14.28(9/16)	
	M-4R		Male BSPT		41.1(1.62)	14.28(9/16)	
SCA2	M-8N	1.20	1/2"	Male NPT		65.0(2.56)	22.22(7/8)
	M-8R		Male BSPT		65.0(2.56)	22.22(7/8)	

To order, add a cracking pressure range designator to the basic ordering number and then specify valve material designator.

Example : SCA1-M-4N-3-S6

Spring Cracking Pressure Range Designator

Designator	Cracking Pressure	
	psi	bar
3	3 to 50	0.21 to 3.5
50	50 to 150	3.5 to 10.4
150	150 to 350	10.4 to 24.2
350	350 to 600	24.2 to 41.4

Pressure-Temperature Ratings

Ratings based on Viton O-ring in SS316 stainless steel valves and NBR O-ring in brass valves.

Series	SCA/SCP	
	Working Pressure, psig (bar)	
	SS316	Brass
-10(-23) to 100(37)	3000(206)	3000(206)
	2575(177)	2600(179)
200(93)	2450(168)	2405(165)
250(121)	2325(160)	-
300(148)	2185(150)	-
375(190)		

SCH60 Series High Pressure Check Valves

↗ Features

- Pressure rating up to 6000psi (413bar) @70°C(21°C).
- Temperature rating up to 375°F(191°C)with standard FKM O-ring.
- S316 Stainless steel body as standard.
- Suitable for gas and liquids.
- Cracking pressures include : 1/3, 1, 5, 10, 25psi.
- Heat code traceability.
- Every valve is 100% factory tested for cracking and reseal.

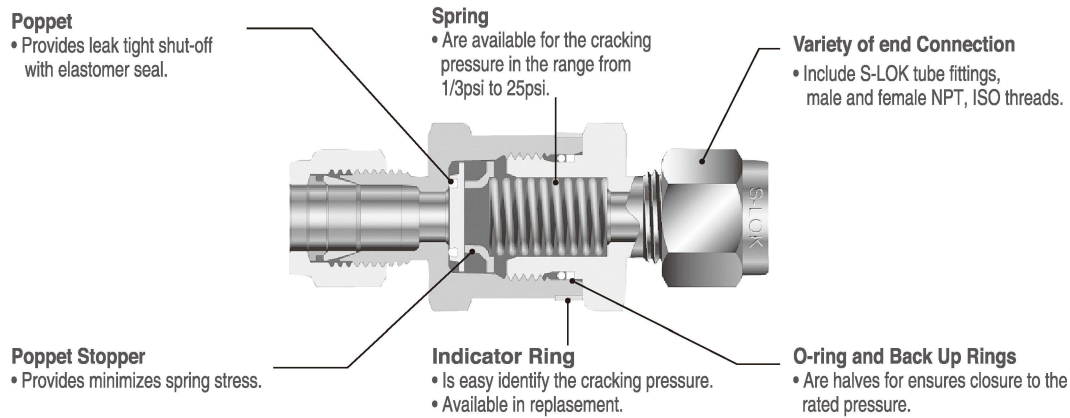

↗ Technical Data

Pressure and Temperating Ratings

Description	SS316		
	SCH1	SCH2	SCH3
Working Pressure and Back Pressure @ 70°F(21°C)	6000psi (413bar)		5000psi (344bar)
Operating Temperature Range	FKM : -10°F to 375°F (-23°C to 190°C)		
Nominal Cracking Pressure	1/3, 1, 5, 10, 25psig		

Optional O-ring Seal Materials

Material	Designator	Temperature Rating°C(°F)	Application
NBR	NB	-20°C to 105°C (-4°F to 221°F)	Petroleum-based hydraulic and lubricating oils, animals and vegetable oils, acetylene, alcohols, air, alkalis, fuel oils and many other media.
FKM (Viton)	VT	-23°C to 190°C (-10°F to 375°F)	High-quality compounds for high temperatures, Synthetic and hydraulic fluids; a wide range of chemicals, heavily oxidizing acids, suitable for vacuum.
EPDM	EP	-45°C to 148°C (-50°F to 300°F)	Chemical resistance : nonflammable hydraulic fluids (Skydrol, Pydraul, Lindol, Cellulube 150, phosphoric esters), pure aniline, fire extinguisher liquids (chlorobromo-methane), acid ;excellent resistance to hot water and steam.
FFKM	KA	-20°C to 275°C (-4°F to 527°F)	Superior compounds for high temperature and most chemicals. This compound combines the chemical properties of PTFE with the mechanical properties of Viton.

* Viton is standard for S316 valves and NBR is standard for Brass valves.

↗ Testing

- Every valve is factory tested for cracking and reseal performance.

Materials of Construction

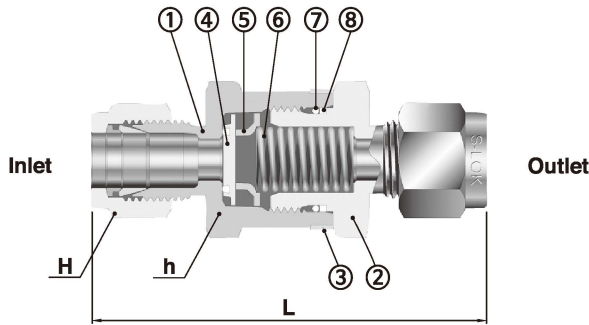

Item	Description	Materials
1	Body	SS316 / A479 or A276
2	Connector	
3	Indicator Ring	
4	Poppet	Viton-bonded SS316
5	Poppet Stopper	SS316 / A479 or A276
6	Spring	SS304
7	O-ring	FKM
8	Back Up Ring	PTFE

* Silicone-based Lubricant for poppet. Wetted parts are listed in orange color.

Dimensions

Basic Ordering Number	Orifice mm	Cv max.	End Connections			Pressure Rating psig(bar)	Dimensions, mm(inch)			
			Size	Inlet	Outlet		L	H	h	
SCH1	4.8	0.67	1/8"	S-LOK		6000(413)	57.7(2.27)	(7/16)	(11/16)	
			1/4"	S-LOK			61.7(2.43)	(9/16)		
			6mm	S-LOK			54.1(2.13)	14.0		
			1/4"	Female NPT			45.5(1.79)	-		
			1/8"	Male NPT			55.1(2.17)			
			1/4"	Male NPT						
SCH2	7.8	1.8	3/8"	S-LOK		6000(413)	69.9(2.75)	(11/16)	(1)	
			1/2"	S-LOK			75.2(2.96)	(7/8)		
			8mm	S-LOK			68.6(2.70)	16.0		
			10mm	S-LOK			71.1(2.80)	19.0		
			12mm	S-LOK		75.2(2.96)	22.0			
			3/8"	Female NPT		5000(344)	64.8(2.55)	-	(1-1/16)	
			1/2"	Female NPT		4600(316)	77.0(3.03)			
			3/8"	Male NPT		6000(413)	59.9(2.36)			
			1/2"	Male NPT		6000(413)	69.3(2.73)			
			1/2"	Female ISO		4600(316)	83.6(3.29)			
			1/2"	Male ISO		6000(413)	69.3(2.73)			
			SCH3	15.0	4.7	3/4"	S-LOK		5000(344)	89.4(3.52)
1"	S-LOK					98.6(3.88)	(1-1/2)			
22mm	S-LOK					88.4(3.48)	32.0			
25mm	S-LOK					98.6(3.88)	40.0			
3/4"	Female NPT					4300(296)	82.0(3.23)	-	(1-5/8)	
1"	Female NPT					4100(282)	97.3(3.83)			
3/4"	Male NPT					5000(344)	83.6(3.29)			
1"	Male NPT					5000(344)	93.2(3.67)			
3/4"	Female ISO					4300(296)	82.0(3.23)			
1"	Female ISO					4100(282)	97.3(3.83)			
3/4"	Male ISO					5000(344)	85.1(3.35)			
1"	Male ISO					5000(344)	93.2(3.67)			

Spring Cracking, Reseal and Back Pressure at @70°F(21°C)

Nominal Spring Cracking Pressure		Applied Working Pressures				Reseal Pressure	
psi	bar	Min. Pressure psi	Max. Pressure bar	psi	bar	psi	bar
1/3	0.02	0	0	3	0.21	Up to 6 Back pressure	0.41
1	0.07	0	0	4	0.28	Up to 5 Back pressure	0.34
5	0.34	3	0.21	9	0.62	Up to 2 Back pressure	0.14
10	0.69	7	0.48	15	1.03	3	0.21
25	1.72	20	1.38	30	2.07	17	1.17

Pressure-Temperature Ratings

Ratings based on FKM O-ring in SS316 stainless steel valves

Series	SCH1, SCH2	SCH3
Temperature°F(°C)	Working Pressure, psig (bar)	
-10(-23) to 100(37)	6000(413)	5000(344)
200(93)	5160(355)	4290(295)
250(121)	4910(338)	4080(281)
300(148)	4660(321)	3875(267)
375(190)	4375(301)	3640(250)
400(204)	4280(294)	3560(245)

Options

Sour Gas Service

- For sour gas application, materials for wetted components are selected according to NACE MR 0175.

Pressure Rating at 70°F(21°C)	SCH1 and SCH2 Series : 5000psig(344bar) SCH3 Series : 4700psig(323bar)
Temperature Rating	-50°F to 300°F(-45°C to 148°C)
Normal Cracking Pressure	1/3, 1, and 5psig(0.02, 0.07, 0.34bar)
End Connections	1/4, 3/8, 1/2, 3/4, and 1" S-LOK Tube Fittings
Material of Construction	Poppet stopper-SS316 Spring-Alloy X750 Back up ring-PTFE Indicator ring-stainless steel

To order, add designator-SG as a suffix to the basic part number with cracking pressure.

Example : SCH1-S-4T-1/3-SG-S6

Fluorocarbon-Free Service

- For system where, PTFE and fluorinated compounds can not be tolerated.

Pressure Rating at 70°C(21°C)	Same as standard product. (See standard technical data)
Temperature Rating	-50°F to 300°F(-45°C to 148°C)
Normal Cracking Pressure	Same as standard product. (See standard technical data)
End Connections	All end connection type and sizes. (See table of dimensions)
Material of Construction	Body, Poppet, Poppet stopper-SS316 Seals-ethylene propylene Spring-SS304 Back up ring-PEEK Indicator Ring-stainless steel Lubricant-hydrocarbon based

To order, add designator-FF as a suffix to the basic part number with cracking pressure.

Example : SCH1-S-4T-1/3-OF-S6

CNG / NGV Certifications

- CNG / NGV Check Valve Series with CNG / NGV Compatible HNBR O-ring are available with CNG / NGV Certifications

Certificates	ECE R110	ANSI NGV 3.1 - 2012	ISO 15500
Certificate No.	110R-010335	126842AUT16	126842MECH105
Classification	Class 0	Manual valve	Manual valve
Temperature	-40 to 120°C (-40 to 248°F)	-40 to 120°C (-40 to 248°F)	-40 to 120°C (-40 to 248°F)
Working Pressure	260 bar @ 120°C	248 bar @ 120°C	260 bar @ 120°C

Ordering Information



- SCH1~3 : Standard
- SCHC~3 : CNG/NGV Service

- 1/3 : 1/3psi
- 1 : 1psi
- 5 : 5psi
- 10 : 10psi
- 25 : 25psi
- NB : NBR
Nil for Brass
- VT : FKM
Nil for SS316
- EP : EPDM
- KA : FFKM

- SG : Sour Gas Service
- OF : Oil Free Service
- S6 : SS316 Stainless Steel
- BS : Brass

SRV Series Relief Valves

Low Pressure Relief Valve – SRV30

- Max. Working Pressure : 300 psi (21 bar)
- Cracking Pressure Range : 10 to 250psi(0.68 to 17.2bar)
- Orifice : 0.19 in. (4.8 mm)

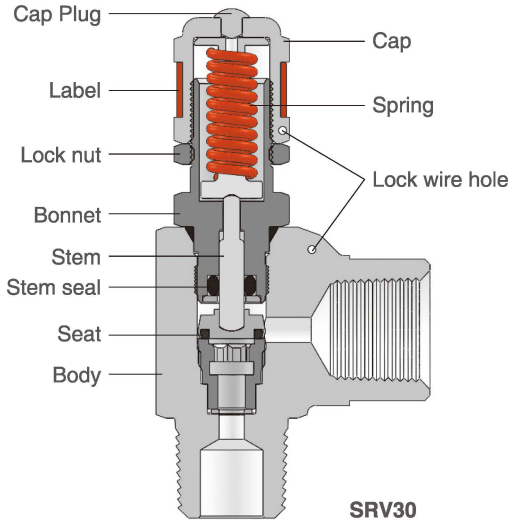

High Pressure Relief Valve – SRV60

- Max. Working Pressure : 6000 psi (413 bar)
- Cracking Pressure Range : 50 to 6000 psi(3.4 to 413 bar)
- Orifice : 0.14 in. (3.6 mm)

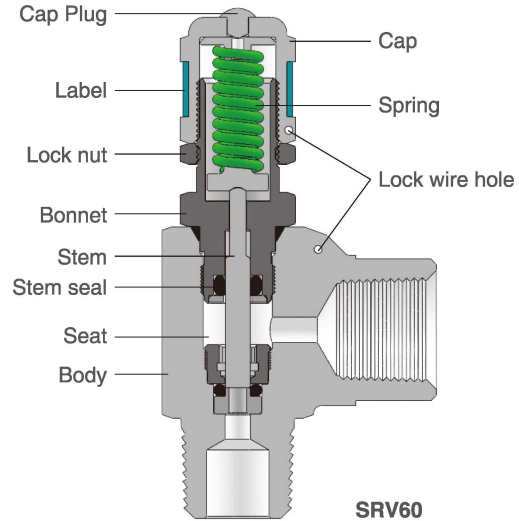

Materials of Construction

Component	Material
Cap Plug	Polypropylene
Cap	SS316 / A276
Bonnet	SS316 / A276
Stem	SS316 / A276
Poppet	SS316 / A276
Seal	FKM (Standard)
Body	SS316 / A182

Applications

SRV series relief valves gradually open as pressure increases. SRV series relief valves have not certified to ASME or any other codes.

Operation

SRV series relief valves open when the system pressure reaches the cracking pressure and close when the system pressure falls below the cracking pressure.

Cracking Pressure

Cracking pressure range of each valve after initial relief. (whichever is greater)

- Below 60°F (15°C) : ± 6 psi (0.4bar) or ± 20 %
- 60 to 80°F (15 to 26°C) : ± 3 psi (0.2bar) or ± 5 %
- Above 80°F (26°C) : ± 6 psi (0.4bar) or ± 20 %

Pressure – Temperature Ratings

Ratings are limited depending on the material. Valves are standard with FKM Seat and Seal.

Temperature, °F (°C)	Max. Cracking Pressure, psi (bar)	
	SRV30	SRV60
-40 (-40) to 70 (20)	250 (17.2)	6000 (413)
150 (65)	250 (17.2)	5580 (384)
200 (93)	250 (17.2)	5160 (355)
250 (121)	250 (17.2)	4910 (338)
275 (135)	250 (17.2)	-
300 (148)	250 (17.2)	-

Seal Material	Designator	Temperature, °F (°C)	
		SRV30	SRV60
FKM	VT	10 ~ 275(-12 ~ 135)	25 ~ 250(-4 ~ 121)
NBR	NBR	-10 ~ 300(-23 ~ 148)	0 ~ 250(-17 ~ 121)
EPDM	EP	-40 ~ 300(-40 ~ 148)	30 ~ 250(-1 ~ 121)
FFKM	KA	-30 ~ 300(-1 ~ 148)	30 ~ 200(-1 ~ 93)

✦ Ordering Information and Dimensions

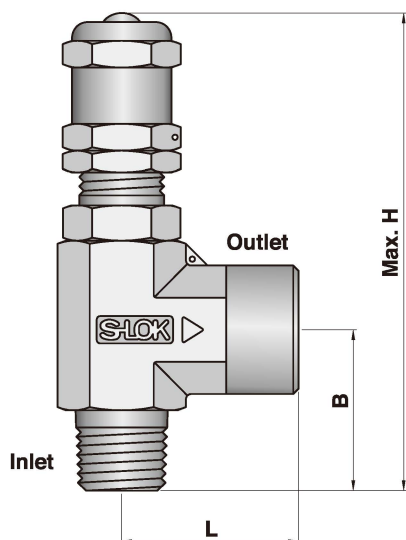

SRV Series Spring

Designator	Cracking Pressure Range		Color
	psi	bar	
SRV30 series spring			
L	10 to 250	0.68 to 17.2	Red
SRV60 series spring			
A	50 to 350	3.4 to 24.1	White
B	350 to 750	24.1 to 51.7	Blue
C	750 to 1500	51.7 to 103	Clear
D	1500 to 2250	103 to 155	Black
E	2250 to 3000	155 to 206	Green
F	3000 to 4000	206 to 275	Yellow
G	4000 to 5000	275 to 344	Brown
H	5000 to 6000	344 to 413	Orange

Basic Ordering NO.	End Connection			Dimensions mm (in.)		
	Inlet / Outlet	Size	H	B	L	
SRV30	S-4T	S-LOK	1/4 "	100 (3.93)	37 (1.45)	39 (1.54)
	S-6T	S-LOK	3/8 "	100 (3.93)	38.5 (1.52)	40.5 (1.59)
	S-8T	S-LOK	1/2 "	105 (4.13)	44 (1.73)	42 (1.65)
	S-6M	S-LOK	6mm	100 (3.93)	38 (1.49)	40 (1.57)
	S-8M	S-LOK	8mm	100 (3.93)	38 (1.49)	40 (1.57)
or	S-12M	S-LOK	12mm	105 (4.13)	44 (1.73)	42 (1.65)
SRV60	MS-8N8T	Male NPT / S-LOK	1/2 "	98 (3.85)	36 (1.41)	42 (1.65)
	MS-8N12M	Male NPT / S-LOK	1/2 " / 12mm	98 (3.85)	36 (1.41)	42 (1.65)
	MF-4N	Male / Female NPT	1/4 "	94 (3.70)	32 (1.25)	30 (1.18)
	MF-6N	Male / Female NPT	3/8 "	94 (3.70)	32 (1.25)	35 (1.37)
	MF-8N	Male / Female NPT	1/2 "	98 (3.85)	36 (1.41)	38 (1.49)

* Dimensions are for reference only and are subject to change. Dimensions shown with S-LOK nuts finger-tight position.

Relief Valve - SRV Series

• The valve contains a spring, and the set pressure must be adjusted. It is possible to supply after setting pressure to desired pressure.

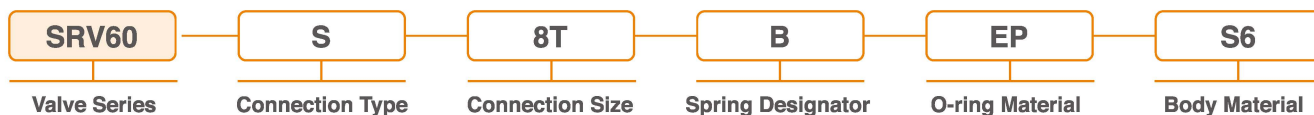

Spring Kit

• Spring kits include spring, label, lock wire with lead seal and replacement instruction



Seal Kit

• Seal kits include poppet, bonnet assembly and replacement instruction



SRV60C Series Relief Valves

Features

- Pressure rating up to 6,000psig (413bar)
- Liquid or gas service
- Adjusts to provide desired set pressure
- Provides elastomer to metal seal for positive shutoff at seat
- Set pressure from 200 psig to 5500 psig

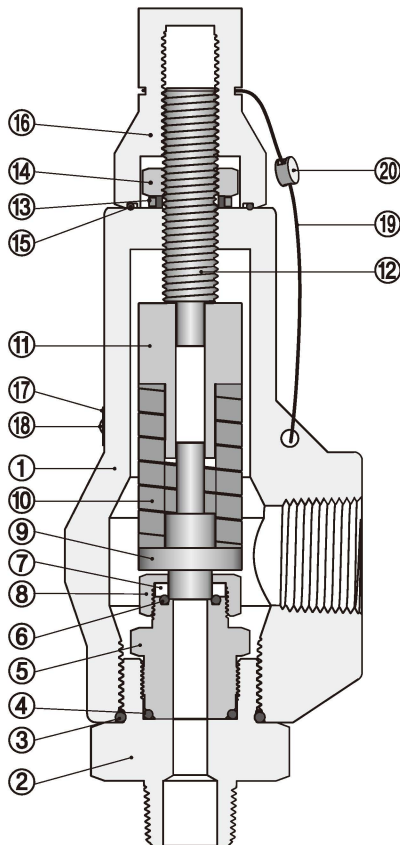

Materials of Construction

No	Component	Material
1	Body	CF3M A351
2	End Connector	SS316 A276/A479
3	O-Ring	FKM
4	O-Ring	FKM
5	Holder	SS316 A276/A479
6	O-Ring	FKM
7	Support	SS316 A276/A479
8	Lock Nut	SS316 A276/A479
9	Stem	SS316 A276/A479
10	Spring	UNS G92540
11	Spring Keeper	Stainless Steel
12	Adjustable Screw	Stainless Steel
13	Thread Seal	NBR + Steel
14	Jam Nut	Stainless Steel
15	O-Ring	NBR
16	Cap	Stainless Steel
17	Nameplate	Stainless Steel
18	Knurled Pin	Stainless Steel
19	Wire	Stainless Steel
20	Lead Seal	Lead(Pb)

↗ Flow Data at 20°(70°)

Air

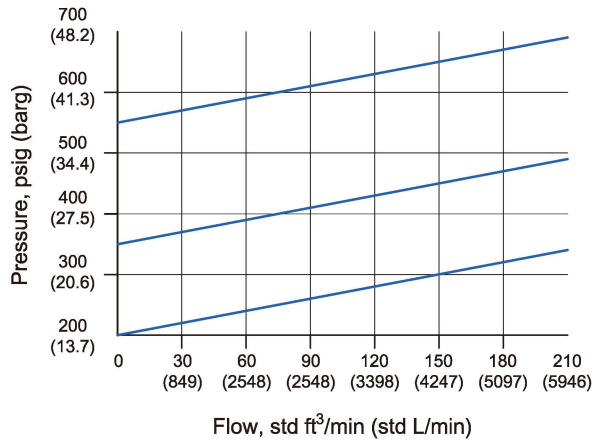

Water

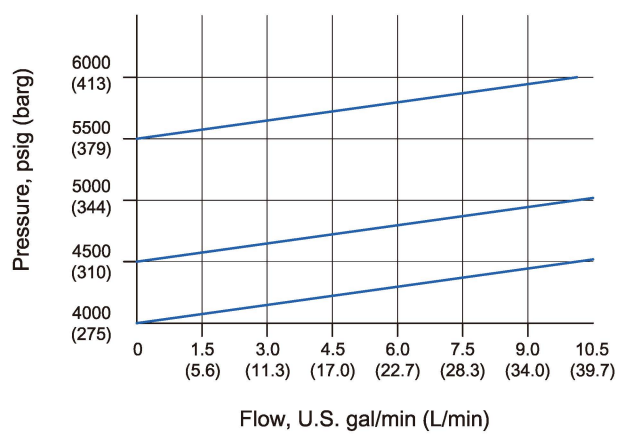
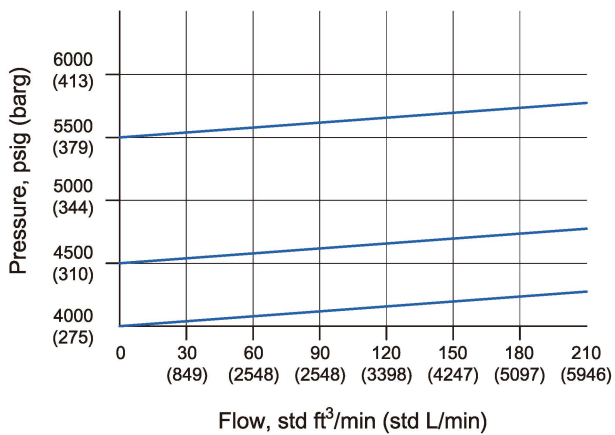
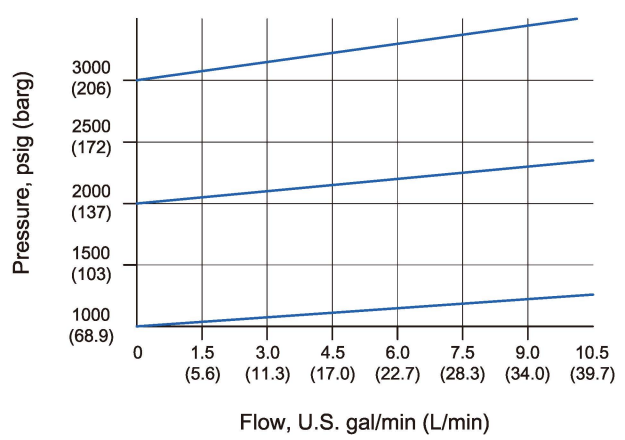
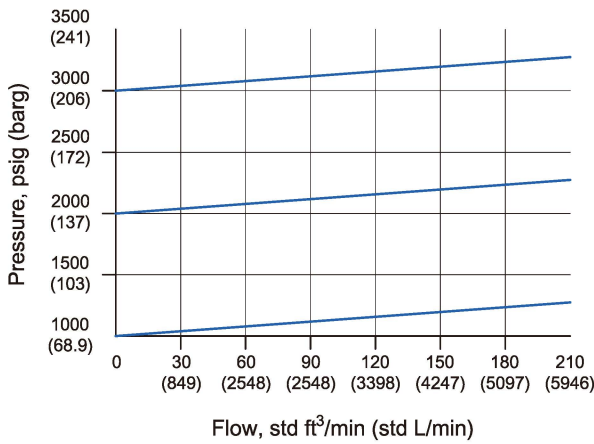
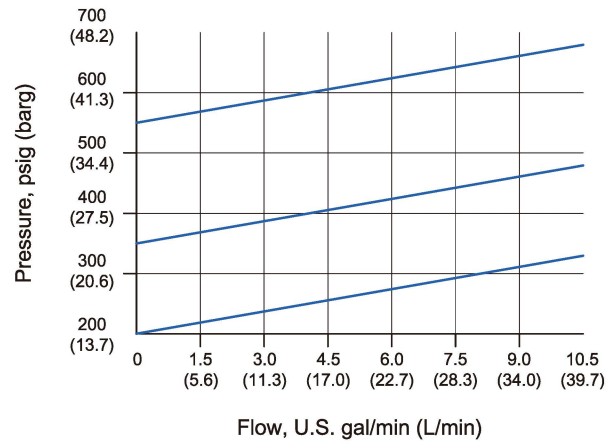

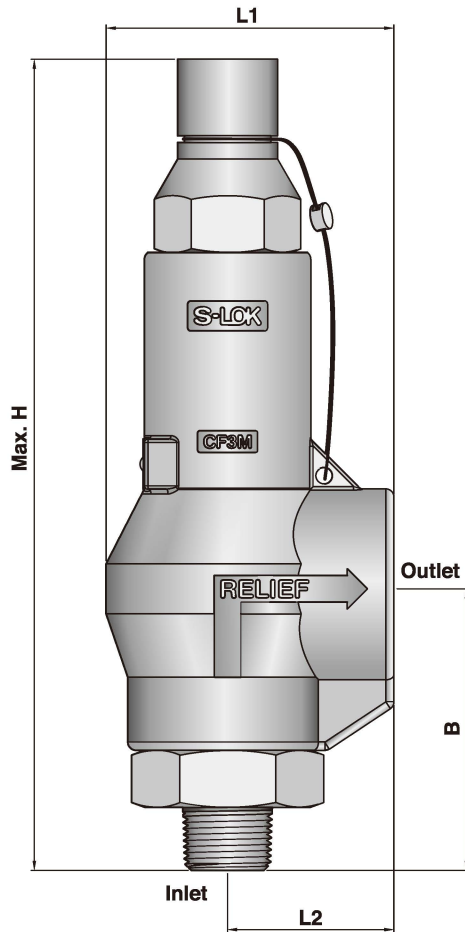

Operation

Usually closed, however it will open when internal pressure reaches the set pressure and re-close when internal pressure falls below the set pressure.

- Valves that were not actuated for a period of time may want initial relief pressure higher than the set pressure.
- Lubricant free valves have higher reseal pressure.
- Resealing pressure is always lower than set pressure.

Options

Seal		
Material	Designator	Temperature Rating °C(°F)
FKM	-	-26 ~ 204(-15 ~ 400)
HNBR	HNBR	-31 ~ 162(-25 ~ 325)
EPDM	EP	-56 ~ 121(-70 ~ 250)

Spring	
Designator	Set Pressure Range psig (barg)
A	200 ~ 750(13.7 ~ 51.7)
B	750 ~ 2500(51.7 ~ 172.3)
C	2500 ~ 5500(172.3 ~ 379.2)

Dimensions

Basic Ordering Number	End Connections		Orifice mm (in.)	Dimensions mm(inch)			
	Inlet	Outlet		H	B	L1	L2
SRV60C	F-8N16N	Female 1/2 NPT	10.0	251.5	84.5	86.5	50.0
	F-12N16N	Female 3/4 NPT					
	MF-8N16N	Male 1/2 NPT					
	MF-12N16N	Male 3/4 NPT					
	MF-16N	Male 1 NPT					

Ordering Information



Safe Valve Selection

The selection of a valve for any application to system design must be considered to ensure performance. Valve function, valve rating material compatibility, proper installation, operation and maintenance remain the sole responsibility of the system designer and the user, S-LOK accepts no liability for any selection, installation, operation or maintenance.

SVRV Series Relief Valves

Features

- Max. Working Pressure : 400psi (27.6bar)
- Cracking Pressure Range : 0.5 to 150psi (0.03 to 10.3bar)
- Temperature rating -20 to 400°F(-28 to 204°C) with standard Viton.
- Various pressure range and spring.
- Factory preset are available.

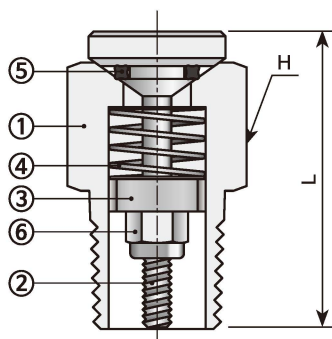

Materials of Construction

Item	Description	Materials	
		SS316	Brass
1	Body	SS316/A276	Brass
2	Stem		
3	Spring Support	SS316	Brass
4	Spring	SS304	
5	Quad Ring	FKM	
6	Lock Nut	Stainless Steel	

Ordering Information and Dimensions

	Basic Ordering Number	End Connection (NPT)	Orifice mm(in.)	Dimensions mm (in.)	
				H	L
SVRV	M-2N	1/8"	4.7(0.187)	24.6(0.97)	12.7(1/2)
	M-4N	1/4"	7.0(0.275)	30.5(1.20)	15.87(5/8)
	M-6N	3/8"	8.8(0.345)	31.5(1.24)	19
	M-8N	1/2"	10.4(0.410)	44.5(1.75)	25.4(1)
	M-12N	3/4"	14.5(0.570)	57.2(2.25)	28.5
	M-16N	1"	19.9(0.785)	79.2(3.12)	38.1(1-1/2)

SVRV Series Spring

Designator	Cracking Pressure Range	
	psi	bar
A	0.5 to 2.5	0.03 to 0.17
B	2.6 to 7.5	0.18 to 0.51
C	7.6 to 15	0.52 to 1.03
D	16 to 35	1.10 to 2.41
E	36 to 75	2.48 to 5.17
F	76 to 125	5.24 to 8.61
G	126 to 150	8.68 to 10.34

Pressure Setting Key

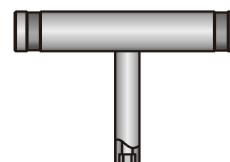

This Pressure Setting Key is to set the cracking pressure by using the hex socket on to the lock nut by turning.

* Ordering No. : SVRV-4-JIG-S6



SEV Series Excess Flow Valves

Operation

The spring loaded poppet remains in the open position during normal system operation. Should an downstream pressure drops the poppet rapidly move to the tripped position, and the downstream line is closed or repaired, when the system pressure equalizes through the bleed vent, the spring automatically resets the poppet to the open position.

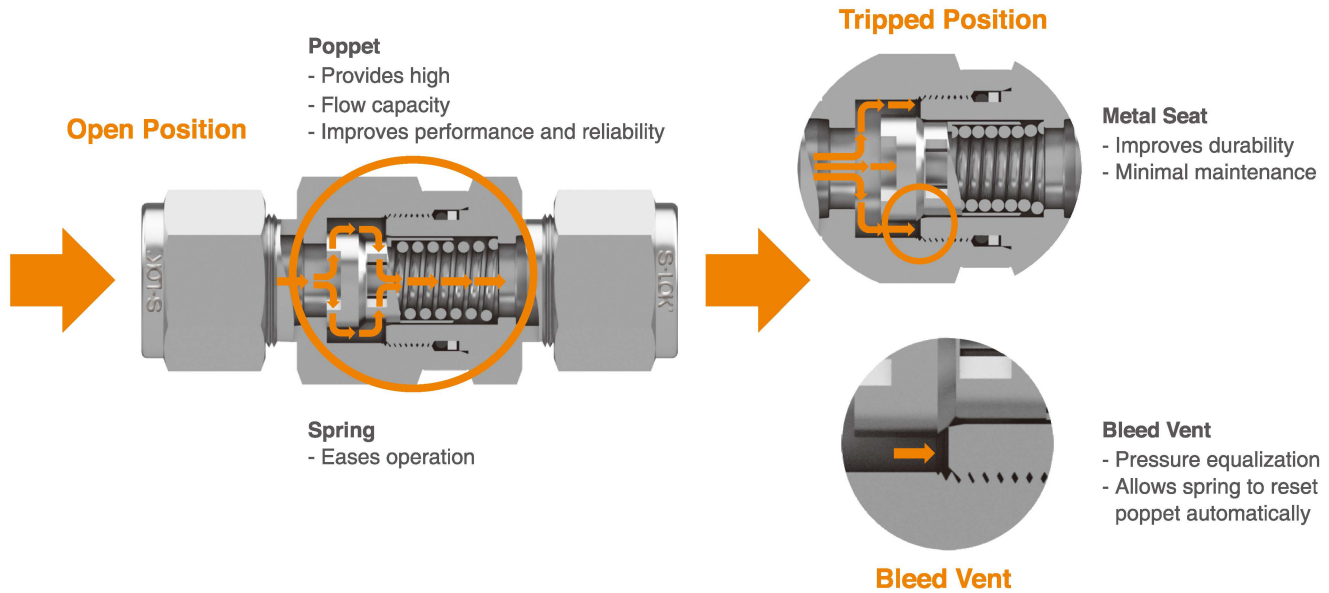

Pressure and Temperature Ratings

Temperature, °F (°C)	Working Pressure, psig(bar)
10 to 100 (-23 to 37)	6000 (413)
200 (93)	5160 (355)
250 (121)	4910 (338)
300 (148)	4660 (321)
400 (204)	4280 (294)

Optional O-Ring Seal Materials

O-Ring Material	Designator	Temperature °F (°C)
FKM	NIL	-10 to 400 (-23 to 204)
NBR	NBR	-4 to 221 (-20 to 105)
EPDM	EP	-50 to 300 (-45 to 148)
FFKM	KA	-10 to 400 (-23 to 204)

Flow Rate at 70°F(20°C)

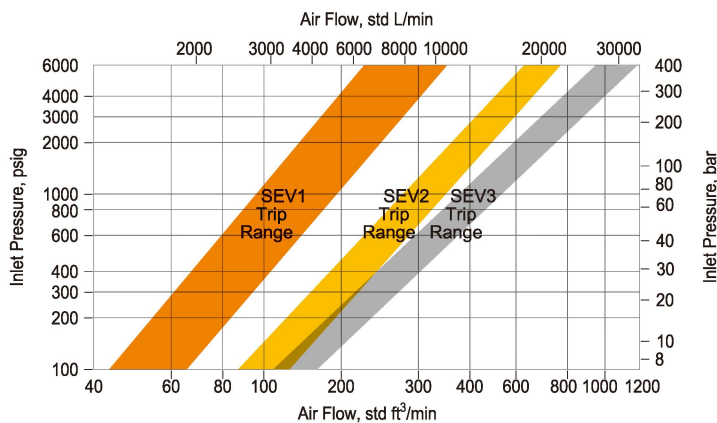

Water

Series	Cv	Trip Range L/min (U.S. gal/min)
SEV1	0.5	14.7 to 21.9 (3.9 to 5.8)
SEV2	1.1	31.0 to 37.8 (8.2 to 10.0)
SEV3	1.1	42.3 to 56.3 (11.2 to 14.9)

Materials of construction

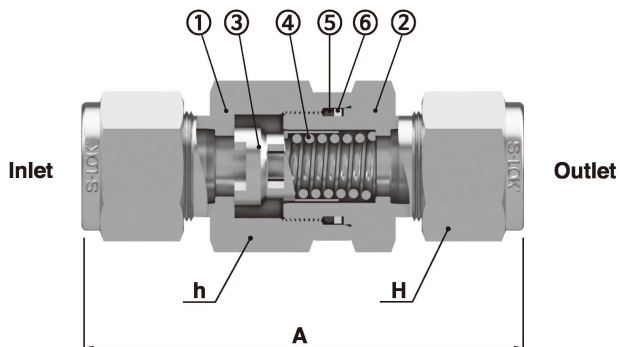

No.	Description	Material	Q'ty
1	Body	SS316 / A276 or A479	1
2	End Connector	SS316 / A276 or A479	1
3	Poppet	SS316 / A276 or A479	1
4	Spring	SS302 / A313	1
5	O-ring	FKM	1
6	Backup ring	PTFE	1

Ordering Information and Dimensions

Basic Ordering Number	End Connection		Dimensions mm (in.)		
	Inlet	Outlet	A	h	H
SEV1	S-4T 1/4" S-LOK		61.9 (2.44)	17.46 (11/16)	14.28 (9/16)
	S-6M 6mm S-LOK		61.8 (2.43)		14
	M-2N 1/8" Male NPT		46.6 (1.83)		-
	M-4N 1/4" Male NPT		46.6 (1.83)		-
	F-2N 1/8" Female NPT		54.6 (2.15)		-
	F-4N 1/4" Female NPT		54.6 (2.15)		-
	MF-4N 1/4" Male NPT 1/4" Female NPT		54.6 (2.15)		-
SEV2	S-6T 3/8" S-LOK		70.2 (2.76)	25.4 (1)	17.46 (11/16)
	S-8M 8mm S-LOK		68.9 (2.71)		16
	S-10M 10mm S-LOK		70.5 (2.77)		19
	M-6N 3/8" Male NPT		61.8 (2.43)		-
	F-6N 3/8" Female NPT		61.8 (2.43)		-
	MF-6N 3/8" Male NPT 3/8" Female NPT		61.8 (2.43)		-
SEV3	S-8T 1/2" S-LOK		75.7 (2.98)	25.4 (1)	22.22 (7/8)
	S-12M 12mm S-LOK		75.8 (2.98)		22
	M-8N 1/2" Male NPT		69.8 (2.74)	27	-
	F-8N 1/2" Female NPT		69.8 (2.74)		-
	MF-8N 1/2" Male NPT 1/2" Female NPT		69.8 (2.74)		-



- NB : NBR
- VT : Viton
- EP : EPDM
- KA : FFKM
- S6 : SS316 Stainless Steel
- BS : Brass